

INSTRUCTION SHEET

MICRO/I™

HG4G / 3G / 2G -V Series



Confirm that the delivered product is what you have ordered. Read this instruction sheet to make sure of correct operation. Make sure that the instruction sheet is kept by the end user.

SAFETY PRECAUTIONS

- Be certain to read this manual carefully before performing installation, wiring, or maintenance work, or operating the MICRO/I.
- This product has been manufactured with careful regard to quality. However, if you intend to use this product in applications where failure of this equipment may result in damage to property or injury, ensure that it used in conjunction with appropriate fail-safe backup equipment.
- In this operation instruction sheet, safety precautions are categorized in order of importance to Warning and Caution:

WARNING

Warning notices are used to emphasize that improper operation may cause severe personal injury or death.

CAUTION

Caution notices are used where inattention might cause personal injury or damage to equipment.

WARNING

- When using the MICRO/I in applications which require high reliability and safety, such as nuclear equipment, railways, aircraft, medical equipment, and vehicles, add a failsafe or backup functionality and verify an adequate level of safety using the product specifications.
- Turn off the power to the MICRO/I before installation, removal, wiring, maintenance, and inspection of the MICRO/I. Failure to turn power off may cause electrical shock or fire hazard.
- Special expertise is required to install, wire, configure, and operate the MICRO/I. People without such expertise must not use the MICRO/I.
- The MICRO/I uses an LCD (liquid crystal display) as a display device. The liquid inside the LCD is harmful to the skin. If the LCD is broken and the liquid attaches to your skin or clothes, wash the liquid off using soap, and consult a doctor immediately.
- Emergency and interlocking circuits must be configured outside of the MICRO/I.
- Do not use touch switches and the function keys for an emergency circuit or an interlocking circuit. If the MICRO/I fails, external equipment connected to the MICRO/I will no longer be protected, and serious injury to operators and equipment damage may be caused.
- Do not use touch switches and the function keys for an emergency circuit or an interlocking circuit. If the MICRO/I fails, external equipment connected to the MICRO/I will no longer be protected, and serious injury to operators and equipment damage may be caused.
- Stop using the MICRO/I if it is accidentally dropped or exposed to significant shocks, check the MICRO/I for damage, and confirm that its various functions work safely and correctly.
- For the MICRO/I connect the FG wire to grounding resistance of 100 Ω or less. Otherwise there is a risk of electric shock or mistaken operation.
- Although the screen will not be visible if the backlight of the MICRO/I burns out, the touch panel will remain functional. Incorrect touch panel operation will occur when operating the touch panel when the backlight appears to be turned off but is actually burnt out. Because such erroneous operation could result in damage, the touch panel should not be used after the backlight has burned out.
- When more than one button is pressed at the same time, due to the detection characteristics of an analog type touch panel, only the gravity center of the pressed area is sensed and the unit assumes that only one button is pressed. Thus, don't operate the MICRO/I by pressing more than one button simultaneously.

CAUTION

- Prevent the MICRO/I from falling while moving or transporting, otherwise damage or malfunction of the MICRO/I will result.
- Use the product within the environmental limits given in the catalog and manual. Use of the product in high-temperature or high-humidity environments, or in locations where it is exposed to condensation, corrosive gas or large shock loads can create the risk of electrocution and fire.
- The MICRO/I is designed for use in pollution degree 2. Use the MICRO/I in environments of pollution degree 2. (based on the IEC60664-1 rating)
- Install the MICRO/I according to the instructions in the User's Manual. Improper installation will result in falling, failure, electrical shock, fire hazard, or malfunction of the MICRO/I.
- Prevent metal fragments or wire chips from dropping inside the MICRO/I housing. Ingress of such fragments and chips may cause fire hazard, damage, and malfunction.
- Use a power supply of the rated value. Using a wrong power supply may cause fire hazard.
- The MICRO/I uses "PS2 of EN61131" as DC power supply. (based on the IEC / EN61131 rating)
- Use wire of a proper size to meet the voltage and current requirements, and tighten the terminal screws of the MICRO/I to the specified tightening torque.
- When exporting the MICRO/I to Europe, use an EN60127 (IEC60127) approved fuse on the power line outside the MICRO/I.
- When exporting the MICRO/I to Europe, use an EU-approved circuit protector.
- Make sure of safety before starting and stopping the MICRO/I. Incorrect operation of the MICRO/I may cause mechanical damage or accidents.
- Use the MICRO/I in a local area network if you download, upload or monitor the project data via the Ethernet port.
- The touch panel of the MICRO/I is made of glass, and will break if exposed to excessive shock. Take due care when handling it.
- Do not push hard or scratch the touch panel and protection sheet with a hard object such as a tool, because they are damaged easily.
- For applications which require clock accuracy, adjust the clock periodically.
- Do not install the MICRO/I in areas subjected to strong ultraviolet rays, since ultraviolet rays may impair the quality of the LCD.
- Do not attempt to disassemble, repair or modify the MICRO/I. This can create the risk of fire or electrocution.
- When disposing of the MICRO/I, do so as an industrial waste.
- Be sure to confirm that the SD Memory Card Access lamp is not lit prior to turning the power off to the MICRO/I or pulling out the SD Memory card. Refer to the User's Manual for details.
- Do not switch off the power or pull out the SD Memory Card or the USB flash drive while it is being accessed, as this may result in destruction of the stored data. If the data on the SD Memory Card or the USB flash drive is corrupted, format the SD Memory Card or the USB flash drive.

UL121201 / CSA C22.2 No.213

- MICRO/I is for indoor use only.
- Open type or panel mounted when installed in an appropriate UL Type 1, Type 4X "Indoor Use Only", Type 12 and/or Type 13 for environmental ratings Type 1, Type 4X "Indoor Use Only", Type 12 and/or Type 13 respectively.
- The use of an SELV source.
- When wiring the MICRO/I at the field, use copper conductors only.
- Terminal Torque as specified in table below:

Type No.HG2G-V5FT22

Type	Torque rating, in.lb.
Power supply	5.0 to 5.3 in.lb.
Serial Communication (COM2)	4 in.lb.

Type No.HG4G-VCXT22, HG3G-VAXT22, HG3G-V8XT22

Type	Torque rating, in.lb.
Power supply	5 in.lb.
Serial Communication (COM2)	2 in.lb.

- Warning - Risk of Fire and Burns. Do not recharge, disassemble, heat above 125°C (257°F) or incinerate.
- Battery shall be replaced by a qualified technician.
- Battery shall be replaced a suitable UL recognized CR2032W battery under UL category BBCV2 rated 3V, 10mA abnormal charge current.
- Avertissement: risque d'incendie et de brûlures. Ne pas recharger, démonter, chauffer à plus de 125°C (257°F), ni incinérer.

Test item particulars	
Type of item	Open Type / enclosed type when panel mounted in appropriate end enclosure
Description of equipment function	Control
Connection to mains supply	N / A connected to SELV source
Overvoltage category	N / A
Pollution degree	2
Means of protection	Class III (Supplied by SELV)
Environmental conditions	Operating or Surrounding Air temperature: -20 to 60 °C Altitude: 2,000 meter maximum operating altitude Humidity: 10 to 90 % Humidity non-condensing
For use in wet locations	Yes; rated Type 1, Type "4X Indoor Use Only", Type 12 and / or Type 13 (when panel mounted)
Equipment mobility	Fixed; Panel mounted
Operating conditions	Continuous
Marked degree of protection to IEC 60529	N / A

- The MICRO/I is suitable for use in Class I, Division 2, Groups A, B, C, D or Non-Hazardous locations only.
- L'appareil MICRO/I est conçu pour être utilisé uniquement dans des emplacements de classe I, division 2, groupes A, B, C, D ou non dangereux.

- Ratings
- Caractéristiques:

Model Series: Série:	Electrical Ratings: Caractéristiques électriques:	Max. Surrounding Air Temp.: Température maximale de l'air ambiant	Temperature Code: Code de température:
HG4G-VCXT22	24 Vdc, 25 W	-20 °C to 60 °C -20°C à +60°C	T4
HG3G-VAXT22			
HG3G-V8XT22	24 Vdc, 22 W		
HG2G-V5FT22	24 Vdc, 18 W		

Enclosure Type 1, Type 4X "Indoor Use Only", Type 12 and/or Type 13
Boîtiers de type 1, de type 4X pour une utilisation intérieure, de type 12 et/ou de type 13.

- Equipment to be installed in an environmentally suitable enclosure that requires the use of a tool to access.
- L'appareil MICRO/I doit être installé dans un boîtier adapté à l'environnement et uniquement accessible à l'aide d'outils.
- "Warning - Explosion Hazard - The Video IN Connection is for initial set up and maintenance only. Do not use, connect, or disconnect unless area is known to be non-hazardous. Connection or disconnection in an explosive atmosphere could result in an explosion"
- Avertissement: Risque d'explosion. La séquence vidéo présentée ne sert seulement qu'à la configuration initiale et à la maintenance de l'appareil. Ne pas utiliser, connecter ou débrancher l'appareil sauf s'il se trouve dans un emplacement non dangereux. Risque d'explosion de l'appareil en cas d'utilisation en atmosphère explosive.

1 Packing Content

Before installing the MICRO/I, make sure that the specifications of the product conform to your requirements, and that no parts are missing or damaged due to accidents during transportation.

- HG4G/3G/2G-V Unit (1)
- Mounting Clips (4) HG4G/3G-V
- HG2G-V
- USB Cable Lock Pin (1)
- Host Communication Plug (1) (Attached to the MICRO/I)
- Screw Lock Bracket Metric Screw Thread (2) M2,6x0,45
- USB Clamp Band (1)
- Instruction Sheet (This manual) (1)

2 Type No.

LCD Size	VIDEO IN / AUDIO OUT	Bezel color	Type No.
12.1 inch	Yes	Black	HG4G-VCXT22MF-B
		Light gray	HG3G-VAXT22MF-W
10.4 inch	Yes	Black	HG3G-VAXT22MF-B
		Light gray	HG3G-V8XT22MF-W
8.4 inch	Yes	Black	HG3G-V8XT22MF-B
		Light gray	HG2G-V5FT22TF-W
5.7 inch	No	Black	HG2G-V5FT22TF-B

3 Part Names

HG4G-V (12.1 inch)

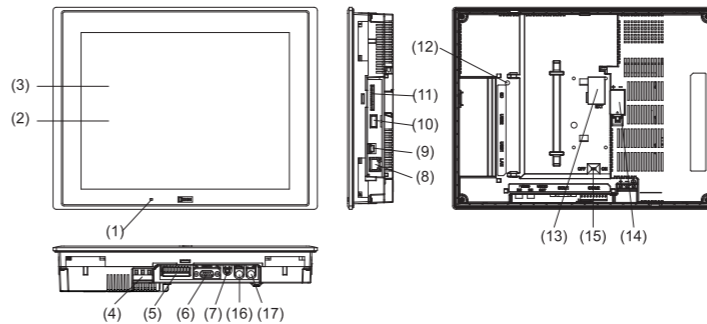

HG3G-VA (10.4 inch)

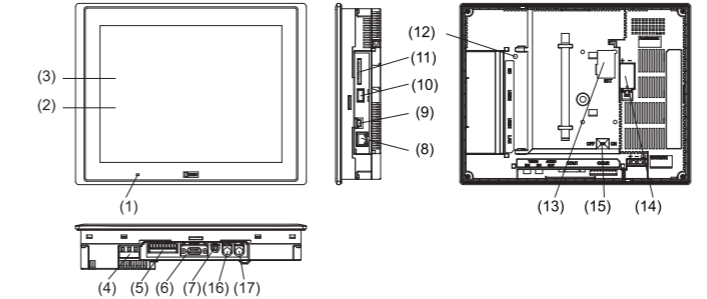

HG3G-V8 (8.4 inch)

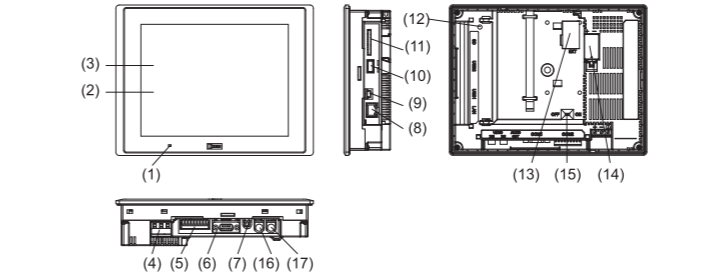

HG2G-V (5.7 inch)

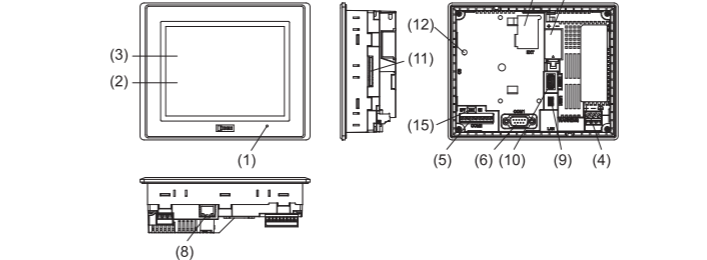

No.	Name	Description
(1)	POWER LED	Green (lit): Normal Operation (Power is ON) Not lit: Power is OFF
(2)	Display	-
(3)	Touch Panel	-
(4)	Power Supply Terminal	-
(5)	Serial Interface (COM2)	RS232C, RS422 / 485 Connector: Terminal Block 9 pin
(6)	Serial Interface (COM1)	RS232C, RS422 / 485 Connector: D-sub 9 pin
(7)	Audio Interface (AUDIO OUT)	LINE OUT (Stereo) Recommended minimum load: 10kΩ Connector: Mini Jack (Ø3.5mm) (Except for HG2G-V)
(8)	Ethernet Interface (LAN)	IEEE802.3i 10BASE-T / 100BASE-TX Connector: RJ-45 (With Auto MDI / MDI-X Function)
(9)	USB Interface (USB1)	USB2.0 (Device) Connector: Mini-B
(10)	USB Interface (USB2)	USB2.0 (Host) Connector: Type A Output current: 5V / 500mA
(11)	Memory Card Interface (SD)	For SD Memory Card
(12)	SD Memory Card Access Lamp	-
(13)	Expansion Unit Interface (EXT)	For IDEC MICROSmart Expansion Modules
(14)	Battery Cover	-
(15)	Terminating Resistor Selector Switch	For COM2 RS422 / 485 Interface
(16)	Video Interface (VIDEO IN1)	NTSC / PAL Connector: Pin Jack (Except for HG2G-V)
(17)	Video Interface (VIDEO IN2)	NTSC / PAL Connector: Pin Jack (Except for HG2G-V)

4 External Interfaces

CAUTION

- Make sure to turn off the power to the MICRO/I before wiring each interface or switching the terminating resistor selector Switch.

4.1 Serial Interface (COM1)

Interface Specification	RS232C, RS422 / 485
Connector	D-sub 9 pin (Plug)
Screw lock Bracket	Inch Screw Thread #4-40 UNC

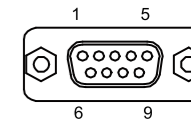

No.	Name	I / O	Function	Communication type
1	RDA	IN	Receive Data (+)	RS422 / 485
2	RD	IN	Receive Data	RS232C
3	SD	OUT	Send Data	RS232C
4	SDA	OUT	Send Data (+)	RS422 / 485
5	SG	-	Signal Ground	-
6	RDB	IN	Receive Data (-)	RS422 / 485
7	RS	OUT	Request to Send	RS232C
8	CS	IN	Clear to Send	RS232C
9	SDB	OUT	Send Data (-)	RS422 / 485

4.2 Serial Interface (COM2)

Interface Specification	RS232C, RS422 / 485
Connector	Detachable Terminal Block 9 pin
Applicable Cable	AWG 20 to AWG 22
Recommended ferrule	AI 0,34-8 TQ, AI 0,5-8 WH, AI TWIN 2x0,5-8 WH (Phoenix Contact) H0,34/12 TK, H0,5/14 OR, H0,5/14 ZH OR (Weidmüller)
Tightening Torque	0,22 to 0,25 N-m



No.	Name	I / O	Function	Communication type
1	SD	OUT	Send Data	RS232C
2	RD	IN	Receive Data	
3	RS	OUT	Request to Send	
4	CS	IN	Clear to Send	
5	SG	-	Signal Ground	RS422 / 485
6	SDA	OUT	Send Data (+)	
7	SDB	OUT	Send Data (-)	
8	RDA	IN	Receive Data (+)	
9	RDB	IN	Receive Data (-)	

Terminating Resistor Selector Switch (for RS422 / 485 interface)



When using RS422 / 485 interface, set the Terminating Resistor Selector Switch to the ON side. This will connect the internal terminating resistor (120Ω) between RDA and RDB.

4.3 Expansion Unit Interface (EXT)

IDEC MICROSmart expansion modules can be connected to the MICRO/I. Refer to the User's Manual for the number, the types and the combination of the expansion modules that can be installed.

5 Specifications

Applicable Standards

Safety Standard	UL61010-1, UL61010-2-201, UL121201 CSA C22.2 No.61010-1-12 (c-UL) CSA C22.2 No.61010-2-201 (c-UL) CSA C22.2 No.213 (c-UL)
EMC Standard	IEC / EN 61131-2
Marine Standard	LR, DNV-GL, ABS, ClassNK

Environmental Specifications

Operating Ambient Temperature	-20 to 60°C		
Operating Relative Humidity	10 to 90% RH (no condensation)		
Storage Ambient Temperature	-20 to 70°C		
Storage Relative Humidity	10 to 90% RH (no condensation)		
Altitude (Operation)	0 to 2,000m		
Pollution Degree	2		
Corrosion Immunity	Free from corrosive gases		

Electrical Specifications

	HG4G-V	HG3G-VA	HG3G-V8	HG2G-V
Rated Operating Voltage	24V DC			
Power Consumption	25W maximum		22W maximum	18W maximum
	When not using USB2 and EXT		15W maximum	8W maximum
Power Voltage Range	20.4 to 28.8V DC		12W maximum	4W maximum
	When the Backlight is off		7W maximum	
Allowable Momentary Power Interruption	10ms maximum			
Inrush Current	30A maximum			
Dielectric Strength	AC1,000V, 10mA, 1minute (between power and earth terminals)			

Construction Specifications

Vibration Resistance	5 to 8.4Hz amplitude 3.5mm 8.4 to 150Hz acceleration 9.8m/s ² 10 times on each of three mutually perpendicular axes (100 minutes) (IEC 61131-2)
Shock Resistance	147m/s ² 11ms (5 shocks on each of three mutually perpendicular axes) (IEC 61131-2)

Performance Specifications					
	HG4G-V	HG3G-VA	HG3G-V8	HG2G-V	
Display	LCD Type *1		TFT color LCD (IPS Type)		
	Display Colors		65,536 Colors		
	Effective Display Area [mm]		245.76(W) × 184.32(H)	210.4(W) × 157.8(H)	170.496(W) × 127.872(H)
	Display Resolution		1,024W × 768H dots		
	View angle		Left / Right / Top / Bottom: 85°		
	Brightness of LCD only		600[cd/m ²]		
	Brightness Adjustment		48 levels		
	Backlight		LED		
	Backlight Life *2		Approx. 100,000 hours		
	Switch Type		Analog Resistive Film		
TouchPanel	Operating Force		3N maximum		
	Multiple Operations		Impossible		
	Life		1,000,000 operations		
	User Memory		Approx. 58MB		
Backup Battery		Coin Type Lithium Manganese Dioxide Battery CR2032W Guarantee Period: 1 Year (at 25°C) Recommended Replacement Span: Every 5 Years (at 25°C)			
Backup Data		Calendar, Log Data, Keep Internal relay / resistor			
Buzzer output		Single tone (tone length is adjustable)			
Degree of Protection*3		IP66F / IP67F (IEC60529) TYPE 4X TYPE 13			
Weight (Approx.)		2.1kg	1.65kg	1.25kg	

*1 Please be aware that small black and bright dots might show up on LCD Screen: it is not a failure or malfunction.

*2 The time until brightness becomes 50% of the initial value.
The life of the LCD itself at an ambient temperature of 25°C. This is not a guaranteed value. The actual life depends on the environment and conditions of use.

*3 It is a protection structure for the operating surface of HMI, which is attached to a panel. Although protection structure suffices every test conditions, it does not guarantee to operate under all of the environmental condition. As for IP66F/IP67F oilproof structure, it suffices oilproof test conditions. Conditions are listed in the document that comes with Japanese Industrial Standard JIS C 0920. Protection structure do not guarantee usage under long exposure to oil or usage of oil that is not prescribed in the document. Please test/check beforehand to avoid trouble.

EMC Specifications	
Radiated Emission *1	Class A: 10m 40dBμV / m quasi-peak (30M to 230MHz) 47dBμV / m quasi-peak (230M to 1GHz)
Electrostatic Discharge	Contact: ±6kV Air: ±8kV
Electromagnetic Field	10V / m (80 to 1000MHz) 3V / m (1.4 to 2.0GHz) 1V / m (2.0 to 2.7GHz) 80% AM (1kHz)
Fast Transient Burst	Power: ±2kV Communication cable: ±1kV
Surge Immunity	±500V (between +24V and 0V) ±1kV (between -24V and FE, 0V and FE)
Conducted Radio Frequency Immunity	3V (Power, Communication cable) (150kHz to 80MHz) 80% AM (1kHz)

6 Dimensions

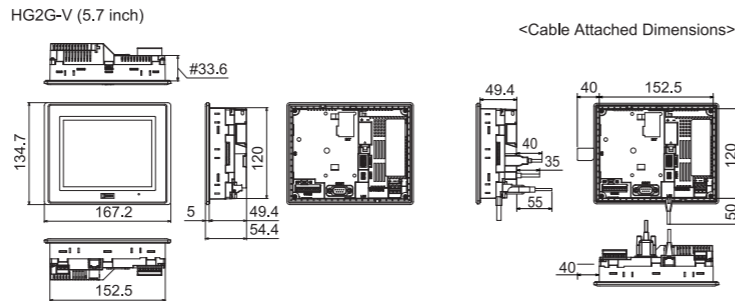
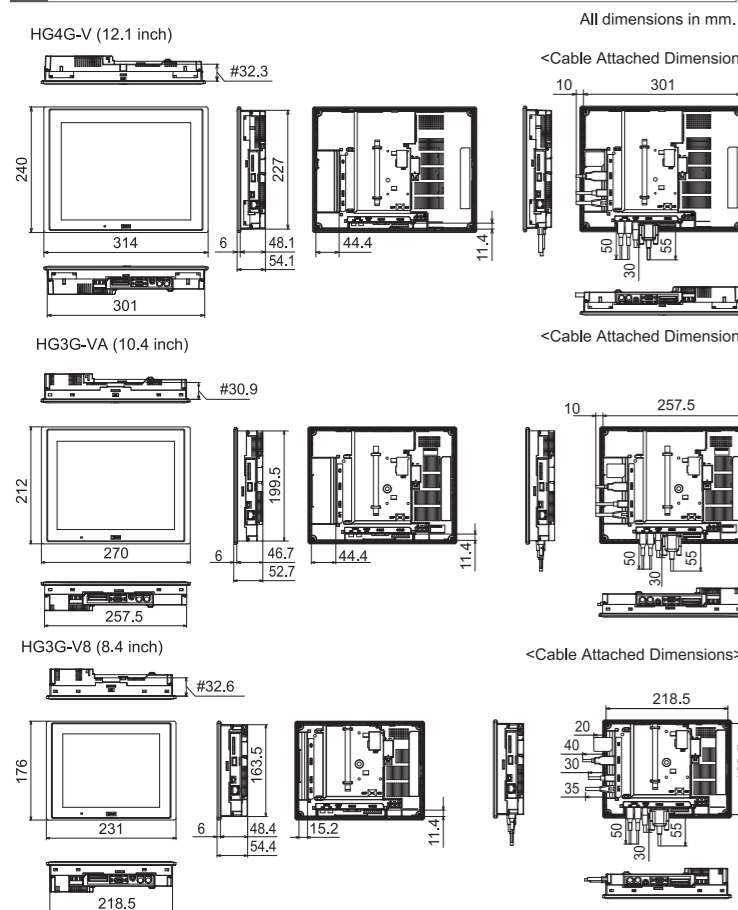

#The size to the expansion module installation side
Depending on the type of connection cable used the dimensions shown above will change.
The dimensions given here are representative values and are intended for reference only.

7 Installation

7.1 Operating Environment

For designed performance and safety of the MICRO/I, do not install the MICRO/I in the following environments:

- Where dust, briny air, or iron particles exist.
- Where oil or chemical splashes for a long time.
- Where oil mist is filled.
- Where direct sunlight falls on the MICRO/I.
- Where strong ultraviolet rays fall on the MICRO/I.
- Where corrosive or combustible gasses exist.
- Where the MICRO/I is subjected to shocks or vibrations.
- Where condensation occurs due to rapid temperature change.
- Where high-voltage or arc-generating equipment (electromagnetic contactors or circuit protectors) exists in the vicinity.

7.2 Ambient Temperature

- Allow sufficient space for ventilation, and install the equipment away from heat sources.
- Allow at least 100mm between the MICRO/I and walls or other equipment.
- Do not install the MICRO/I where the ambient temperature exceeds the rated operating ambient temperature range. When mounting the MICRO/I in such locations, provide a forced air-cooling fan or air-conditioner to keep the ambient temperature within the rated temperature range.
- The MICRO/I is designed to install on a vertical plane so that natural air-cooling is provided. If you install it using any other orientation, use forced-air cooling, or lower the ambient operating temperature.

7.3 MICRO/I Installation

- Make a panel cut-out on the panel with the dimensions shown below.

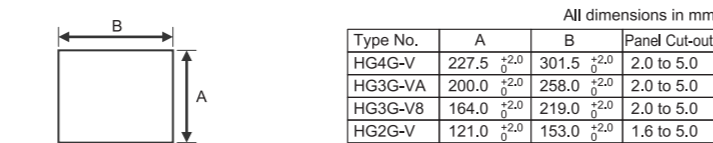

- Place the MICRO/I in a panel cut-out and fasten with the attached mounting clips at four places of the top and bottom side to a specified torque uniformly.
- The HG4G-V, HG2G-V has the mounting clip positions not only on the top and bottom side but also on the left and right side. But when fasten with the attached mounting clips at the left and right side, the HG4G-V, HG2G-V may impair the waterproof, the vibration resistance, and the shock resistance characteristics.

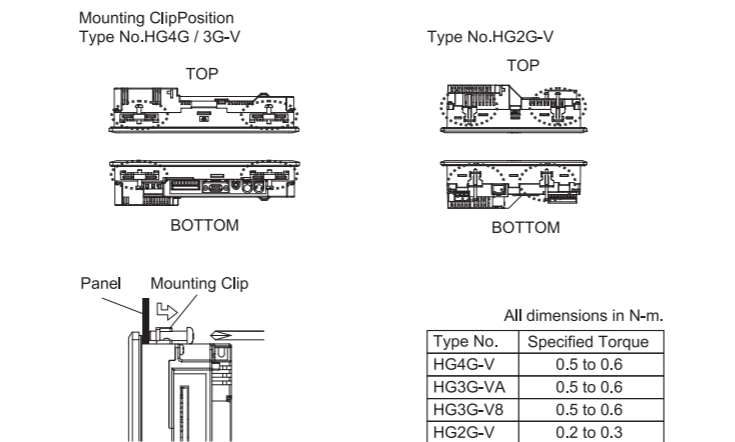

CAUTION

- Do not tighten excessively, otherwise the MICRO/I may warp and cause wrinkle on the display, or impair the waterproof characteristics.
- If the mounting clips are tightened obliquely to the panel, the MICRO/I may fall off the panel.
- When installing the MICRO/I into a panel cut-out, make sure that the gasket is not twisted. Especially when re-installing, take special care because any twists in the gasket will impair the waterproof characteristics.

7.4 MICRO/I Orientation

The MICRO/I is designed to install on a vertical landscape. If you install it using any other orientation, confirm the limitations about operating ambient temperature and the use of MICROSmart expansion modules.

Orientation	Type No.	Operating Ambient Temperature	
		w/o expansion modules	w/ expansion modules
Landscape	HG4G-V	-20 to 60°C	-10 to 50°C
	HG3G-V		
	HG2G-V		
Portrait (Clockwise)	HG4G-V	-20 to 60°C	unavailable
	HG3G-V		
	HG2G-V		
Portrait (Counter Clockwise)	HG4G-V	-20 to 60°C	unavailable
	HG3G-V		
	HG2G-V		
Horizontal	HG4G-V	-20 to 60°C	unavailable
	HG3G-V		
	HG2G-V		

<Note>
When installing the MICRO/I in a diagonal, the limitations are same as a horizontal. Confirm the visibility of the display in a final installation.

8 Wiring

CAUTION

- Turn off the power supply before wiring.
- Make the wiring as short as possible and run all wires as far away as possible from high-voltage and large-current cables. Follow all the procedures and precautions when wiring the MICRO/I.
- Separate the MICRO/I power supply wiring from the power lines of I/O devices and motor equipment.
- Ground the functional earth terminal to make sure of correct operation.

8.1 Power Supply Terminal

Pin assignment is shown in the following table.

+	Power supply 24V DC (+24V)
-	Power supply 0V (0V)
	Functional Earth (FE)

- Use applicable cables for wiring and recommended ferrule (made by Phoenix Contact or Weidmüller) as follows.

Type No.	HG4G / 3G-V	HG2G-V
Applicable Cable	AWG 18 to AWG 22	AWG 14 to AWG 22
Recommended ferrule	AI 0,34-8 TQ, AI 0,5-8 WH, AI 0,75-8 GY, AI 1-8 RD, AI TWIN 2x0,5-8 WH, AI TWIN 2x0,75-8 GY, AI TWIN 2x1-8 RD (Phoenix Contact) H0,34/12 TK, H0,5/14 OR, H0,75/14 W, H1,0/14 GE, H0,5/14 ZH OR, H0,75/14 ZH W, H1,0/15 ZH GE (Weidmüller)	AI 0,34-12 TQ, AI 0,5-12 WH, AI 0,75-12 GY, AI 1-12 RD, AI 1,5-12 BK, AI 2,5-12 BU, AI TWIN 2x1,5-12 BK (Phoenix Contact) H0,5/18 OR, H0,75/18 W, H1,0/18 GE, H1,5/18D SW, H2,5/19D BL, H1,5/20 ZH R (Weidmüller)
Tightening Torque	0,5 to 0,6 N-m	0,5 to 0,6 N-m

8.2 Grounding Cautions

If you decide to use a single power supply for the MICRO/I with more than one external device, take extra precautions. Some external devices may produce electrical noise and short circuit the entire system setup, therefore, damaging the communication circuit of the MICRO/I and non-isolated Communication Device (i.e. PLC).

To prevent such damage, choose a proper solution depending on your system setup.

- Use a separate earth ground from the external noise source device.
- The wire for grounding should be thick and short in order to direct the noise from the noise source device to the earth ground.
- Use a separate power supply from the external noise source device.
- Insert an isolator on the communication line of the MICRO/I and the non-isolated communication device (i.e. PLC) to prevent damage.

9 USB Cable Lock Pin Attachment

When using the USB device, attach the USB Cable Lock Pin to prevent disconnecting the USB cable from the MICRO/I.

-
- (1) Insert the USB cable into the USB2 port.
 - (2) Strain the [Edge part] of the USB Cable Lock Pin, and insert the [Edge part] to the 2 holes upper the USB2 port.
 - (3) Fasten the USB Clamp Band around the USB cable and the [Clamp part], secure them tightly.

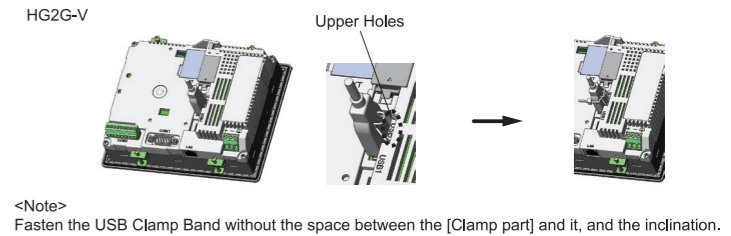
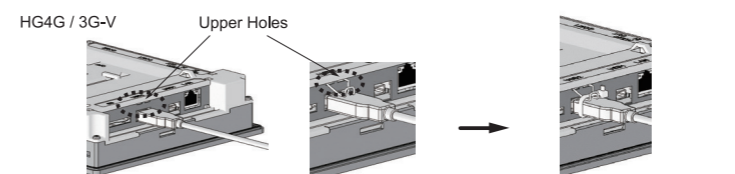

<Note>
Fasten the USB Clamp Band without the space between the [Clamp part] and it, and the inclination.

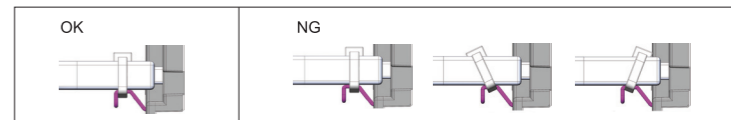

10 Maintenance and Inspection

Maintain and inspect the MICRO/I periodically to ensure the best performance. Do not disassemble, repair, or modify the MICRO/I during inspection.

Display	Wipe any stain of the display using a soft cloth slightly dampened with neutral detergent or alcoholic solvent. Do not use solvents such as thinner, ammonia, strong acid, and strong alkaline.
Terminals, Connectors	Check the terminals and connectors to make sure of no loose screws, incomplete insertion, or disconnected lines.
Mounting Clips	Make sure that all mounting clips and screws are tightened sufficiently. If the mounting clips are loose, tighten the screw to the recommended tightening torque.
Backlight	The MICRO/I's backlight cannot be replaced by the customer. When the backlight needs to be replaced, Contact IDEC.
Backup Battery	The operating life of the internal battery is approximately five years. It is recommended to replace the battery every five years even before the reminder message for battery replacement is displayed.
Touch Panel	A gap may be caused in the operation accuracy of the touch panel by the secular distortion, etc. Readjust the touch panel according to the following procedure when there is a gap in the operation of the touch panel.

10.1 Replacing the Backup Battery

A backup battery is built into the MICRO/I to retain the internal backup data (log data, keep resistor, and keep relay) and clock data.
When the "Replace the battery" message is displayed, replace the backup battery by following the procedure below.
When the "Battery level LOW" message is displayed, replace the battery immediately; otherwise, the backup data and clock data may be lost.
Whether or not to display the reminder message for battery replacement can be specified with the configuration software. Refer to the User's Manual for details.

- (1) Remove the battery holder cover.
- (2) Turn on the power to the MICRO/I, wait for approximately one minute, and then turn off the power again.

<Note>
After turning off the power to the MICRO/I in step (2), complete the steps through (4) within 30 seconds to replace the battery without losing the backup data and clock data.
However, it is recommended that the backup data be transferred to flash memory as a precautionary measure. For the procedure to transfer the data to flash memory, refer to the User's Manual. If it is not necessary to save the data, step (2) can be skipped.

- (3) Remove the battery from the battery holder.
- (4) Put a new replacement battery into the battery holder. Do not insert the battery reversely.
- (5) Replace the battery holder cover into the original position.

- The operating life of the internal battery is approximately five years. It is recommended to replace the battery every five years even before the reminder message for battery replacement is displayed.
- IDEC provides replacement service for the battery (at customer's expense). Contact IDEC.

WARNING

The battery may be regulated by national or local regulation. Observe the instructions of proper regulation. As electric capacity is left in a discarded battery and it comes into contact with other metals, it could lead to distortion, leakage, overheating, or explosion, so make sure to cover the (+) and (-) terminals with insulating tape before disposal.

CAUTION

When replacing the battery, use the specified battery only. Note that any problems and failures arising from or in connection with the use of a battery other than the specified battery is not guaranteed.

Handling of Batteries and Devices with Built-in Batteries in EU Member States

<Note>
The following symbol mark is for EU countries only.



This symbol mark means that batteries and accumulators, at their end-of life, should be disposed of separately from your household waste.
If a chemical symbol is printed beneath the symbol shown above, this chemical symbol means that the battery or accumulator contains a heavy metal at a certain concentration. This will be indicated as follows:

Hg : Mercury (0.005%) Cd : Cadmium (0.002%)
In the European Union there are separate collection systems for used batteries and accumulators. Please dispose of batteries and accumulators correctly in accordance with each country or local regulation.

IDEC CORPORATION

http://www.idec.com
Manufacturer : IDEC CORP, 2-6-64 Nishimiyahara, Yodogawa-Ku, Osaka 532-0004, Japan
EU Authorized Representative : APEM SAS
55, Avenue Edouard Herriot BP1, 82303 Caussade Cedex, France